

SAFETY INSTRUCTIONS

WARNING

1. 120 Volts may cause serious injury from electric shock. Disconnect electrical power before starting installation or servicing. Leave power disconnected until installation/service is completed.
2. Sharp edges may cause serious injury from cuts. Use care when cutting plenum openings and handling duct work.
3. Dropping may cause personal injury or equipment damage. Handle with care and follow installation instructions.

CAUTION

1. Read all instructions before beginning installation.
2. Improper installation may cause property damage or injury. Installation, service, and maintenance must be performed by a qualified service technician.
3. Do not use in pool applications. Pool chemicals can damage the dehumidifier.
4. Do not use solvents or cleaners on or near the circuit board. Chemicals can damage circuit board components.
5. Wait 24 hours before running the unit if it was not shipped or stored in the upright position
6. Do not use dehumidification to prevent window condensation in the winter. To address window condensation, use ventilation to lower indoor humidity in the winter.

READ AND SAVE THESE INSTRUCTIONS

TABLE OF CONTENTS

Safety Instructions	1
Specifications	3
Set Up Dehumidifier for Installation	3
Duct Collars	4
Control Location	5
Hard Wiring	6
Electrical Specifications for Hard Wiring	6
Wiring Instructions	7
Location Considerations	8
Drain Installation	9
Leveling	9
Condensate Pan, Condensate Pump and Float Switch	9
Ducting to HVAC System – Basement and Attic Installations	10
Ducting to HVAC System – Closet Installations	11
Ducting for Stand Alone Installations or Non-Ducted Installations	11
Ducting for Two Zone Installations	12
Model 76 – External Control or Crawl Space/Sealed Attic Control and Wiring	13
Wiring the Dehumidifier to the HVAC System and Zone Dampers	14
System Set Up and Checkout	15
Installer Test Mode	17
Start Up and Sequence of Operation	18
Single Zone Whole House or Stand Alone Using the Dehumidifier Control	18
Single Zone Whole House or Stand Alone Using Model 76 External Control	18
Crawl Space (Remote) Control Using Model 76	18
Two Zone – Primary and Secondary	18
Ventilation	19
Installation and Wiring	19
Vent Auto & Vent-Timed	20
Outdoor Temperature Sensor Installation	20
Determine Ventilation Requirements	21
Installer Settings	22
Sequence of Operation	23
Troubleshooting	24
Table 4 – Diagnostic Codes	24
Table 5 – Troubleshooting Guide	26
Service Parts	27

SPECIFICATIONS

	Model 1830		Model 1850 & 1850W	
Weight	67 lbs.		70 lbs.	
Capacity AHAM DH-1-2008 80°F, 60% RH Conditions	70 pints per day @ 160 CFM		95 pints per day @ 245 CFM	
Power 115 VAC, Single Phase, 60Hz	6.3A operating current		8A operating current	
Dehumidifier Inlet Air Conditions	Dehumidification: 50°F – 104°F, 40°F dew point minimum Ventilation: 40°F – 140°F, 0%RH – 99%RH (non-condensing)			
Filter	MERV 8, washable			
Airflow	External Static Pressure ("w.c.)	Airflow (CFM)	External Static Pressure ("w.c.)	Airflow (CFM)
	0.0	160	0.0	245
	0.2	120	0.2	215
	0.4*	75	0.4	185
			0.6*	150

*Maximum design external static pressure.

SET UP DEHUMIDIFIER FOR INSTALLATION

⚠ IMPORTANT: Cut the strap securing the compressor shipping support bracket and remove the strap and shipping bracket. See **Figure 1**.

FIGURE 1 – Remove Shipping Bracket

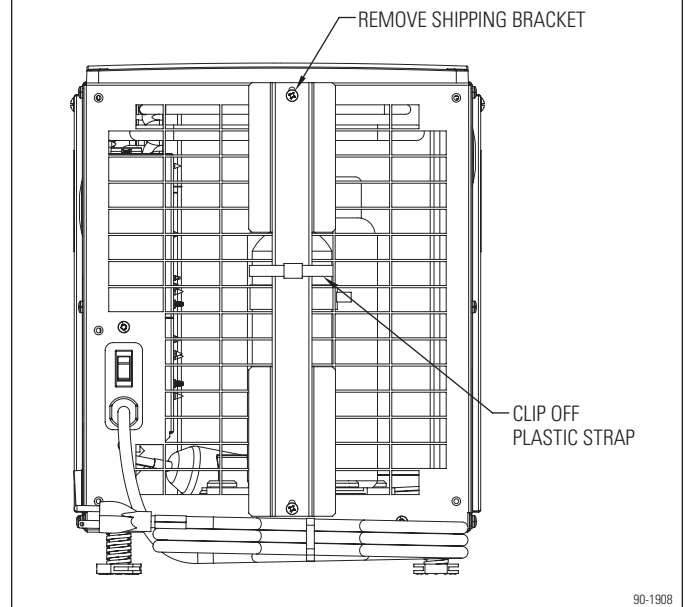

90-1908

SET UP DEHUMIDIFIER FOR INSTALLATION (CONTINUED)

DUCT COLLARS

STANDARD BASEMENT AND ATTIC INSTALLATIONS (FULLY DUCTED)

- Use the screws in the parts bag to attach the duct collars to the inlet and outlet of the dehumidifier. The outlet collar has a backflow damper.
- The outlet duct collar may be attached to the top or end of the unit. Move the outlet cover to the location not being used. See **Figure 2**.
- Make sure there are no bends in the ductwork coming off the outlet for a minimum of 4". This will ensure that the ductwork will not interfere with the backflow damper function.

CLOSET INSTALLATIONS

Use the screws provided in the parts bag to attach the duct collars if desired or required based on recommendations below:

- Where inlet space is restricted, the inlet duct collar is optional.
- When the dehumidifier is installed below the HVAC equipment and requires a vertical discharge, move the top access panel to the end of the unit. The outlet duct collar with backflow damper is not required. See **Figure 3**.
- When the dehumidifier requires a ducted vertical discharge, remove the top access panel and remount on the outlet of the unit. Install the outlet duct collar with backflow damper on top of the unit. See **Figure 3**.

CRAWL SPACE, SEALED ATTICS OR BASEMENT INSTALLATIONS

If dehumidifying the space in which the dehumidifier is installed, the duct collars do not need to be installed. Leave the outlet cover on top of the unit. See **Figure 4**.

FIGURE 2 – Fully Ducted Installations

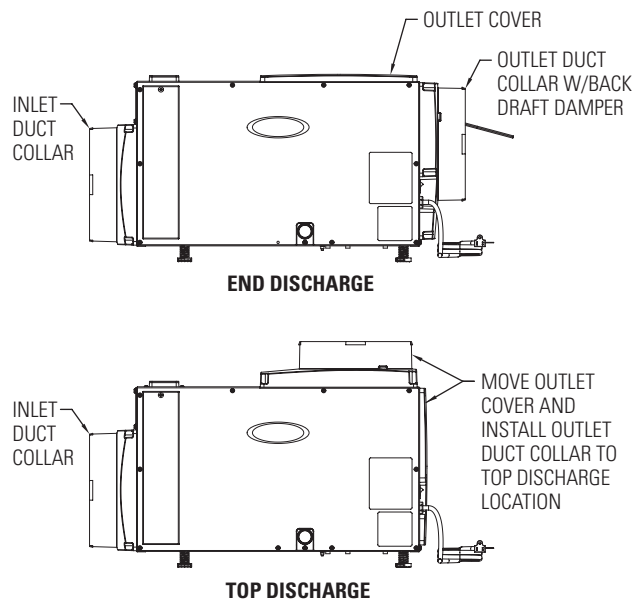

FIGURE 3 – Closet Installations

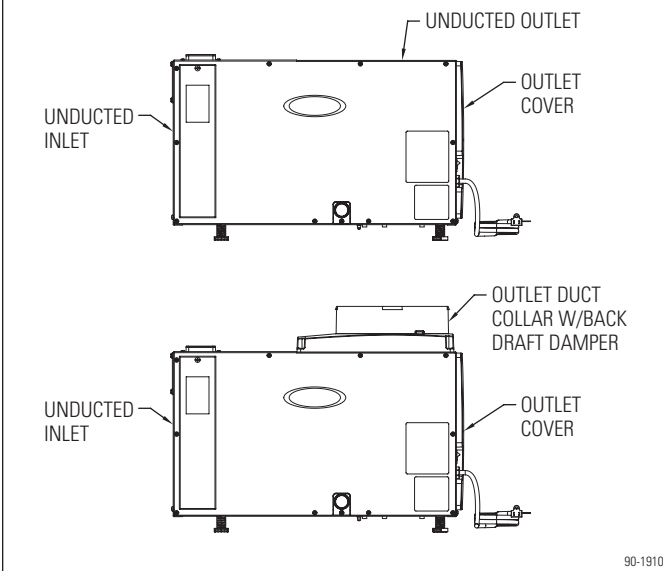
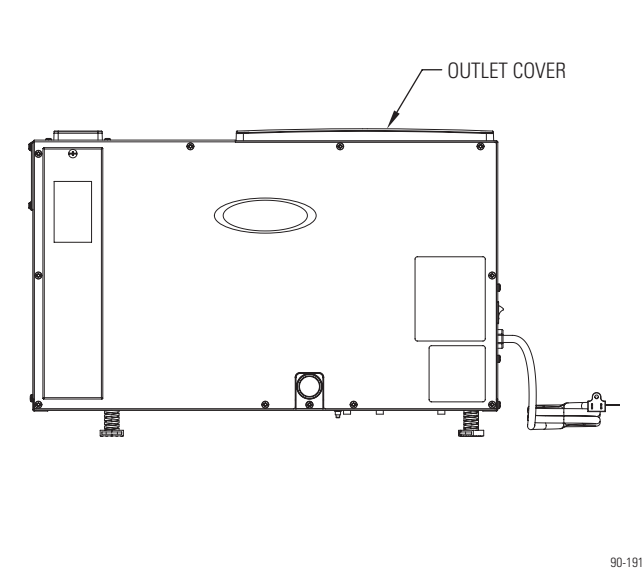

FIGURE 4 – Non-ducted Installations



SET UP DEHUMIDIFIER FOR INSTALLATION (CONTINUED)

CONTROL LOCATION

The on-board control can be located on the top of the dehumidifier or can be relocated to the front of the dehumidifier if the control can not be seen/accessed in the top orientation.

To move the control:

1. Remove the front control panel cover.
2. Remove the filter access door and filter.
3. Detach the on-board control by removing the four (4) screws around the control. **NOTE:** Use one hand to support the bottom of the on-board control when removing.
4. Keep the control in the unit and relocate to the front access hole.
5. Secure the control with the same four screws used to attach the control to the top of the unit.
6. Secure the control panel cover to the top of the unit.

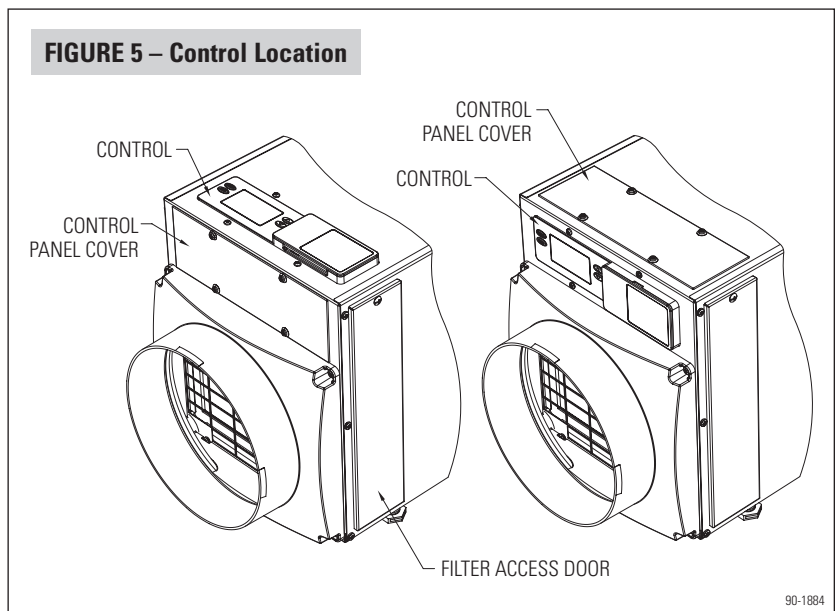

HARD WIRING

WARNING

ELECTRICAL SHOCK HAZARD: 115-volts may cause serious injury or death from electrical shock. Disconnect and tag electrical service before starting installation or field-service. Leave electrical service disconnected until installation or field-service is complete.

ELECTRICAL SHOCK HAZARD: An interrupted or broken ground may cause property damage, serious injury or death should an electrical fault occur. The cabinet must be grounded in accordance with NEC ANSI/NFPA 70-2011 or local codes. In Canada, refer to Canadian Electrical Code CSA C22.1.

FIRE HAZARD: Use of improper wire may cause serious injury, property damage or death due to fire. Do not use aluminum wire for electrical service to the dehumidifier. Use only copper wire.

CAUTION

Use of an undersized circuit breaker may cause property damage and/or the need for mold remediation service. See Specifications for wire and circuit breaker sizing.

The Model 1830 dehumidifier can be modified for applications where hard wire power to 115VAC is required; the Model 1850W must be hard wired. An electrical disconnect switch can be installed as needed to comply with appropriate codes or ordinances. The ON/OFF switch on the dehumidifier interrupts the 115VAC service to the internal components of the dehumidifier, but does not disconnect the power supply at the 115VAC terminals on the dehumidifier.

United States Installations: Make all electrical connections in accordance with the current edition of the NEC ANSI/NFPA 70 and any local codes or ordinances that may apply.

Canada Installations: Make all electrical connections in accordance with the current edition of the Canadian Electrical Code CSA C22.1 and any local codes or ordinances that may apply.

ELECTRICAL SPECIFICATIONS FOR HARD WIRING MODEL 1830 & 1850W

	Model 1830	Model 1850W
Voltage	110-120 VAC, 60 Hz, 1 phase	110-120 VAC, 60 Hz, 1 phase
Minimum Circuit Capacity	9A	12A
Maximum Fuse or Circuit Breaker Amps	16A	20A
Minimum Wire Size AWG	14	14

HARD WIRING (CONTINUED)

WIRING INSTRUCTIONS

1. Disconnect electrical service at the main fuse or circuit breaker box.
2. Install any code required electrical disconnects to the line service.
3. Remove the side panel and electrical service panel from the dehumidifier. See **Figure 6**.
4. **Model 1830 only:** Disconnect the power cord connections from the terminals in the electrical service box. See **Figure 7**.
5. **Model 1830 only:** Use pliers to pinch the strain relief and pull it out of the dehumidifier cabinet along with the power cord. See **Figure 6**.
6. Route the service cable through the 7/8" diameter hole where the power cord was removed. USE ONLY COPPER SUPPLY WIRES.
7. Secure the cable/conduit to the dehumidifier using fittings/connectors approved for the type of cable/conduit used.
8. Connect the ground wire of the service cable to the ground lug in the electrical service box. See **Figure 7**.
9. Connect the line voltage wires of the service cable to the LINE BLK and NTRL WHT terminals. See **Figure 7**.
10. Reattach the electrical service panel and side panel.
11. Restore electrical service at the main fuse or circuit breaker box.

FIGURE 6 – Electrical Service Box Location

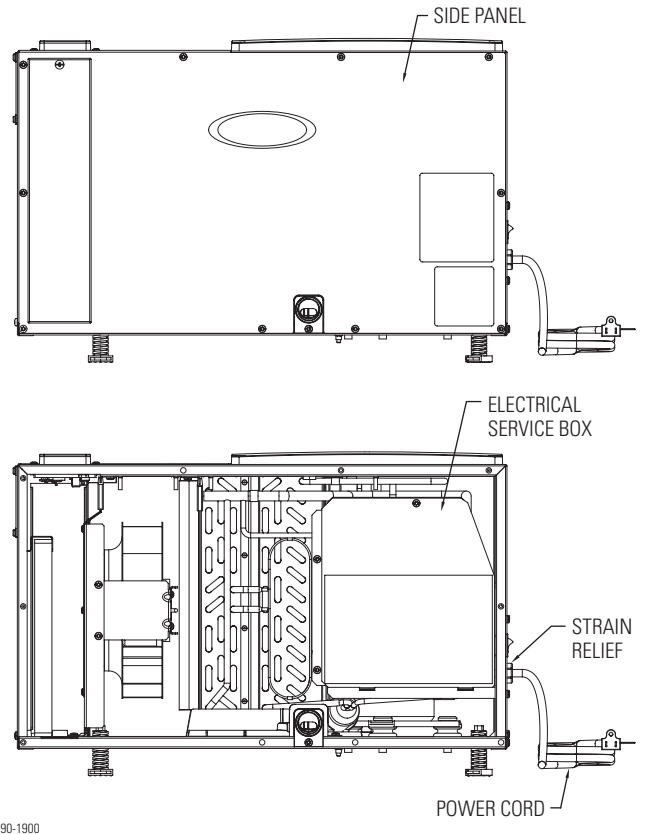
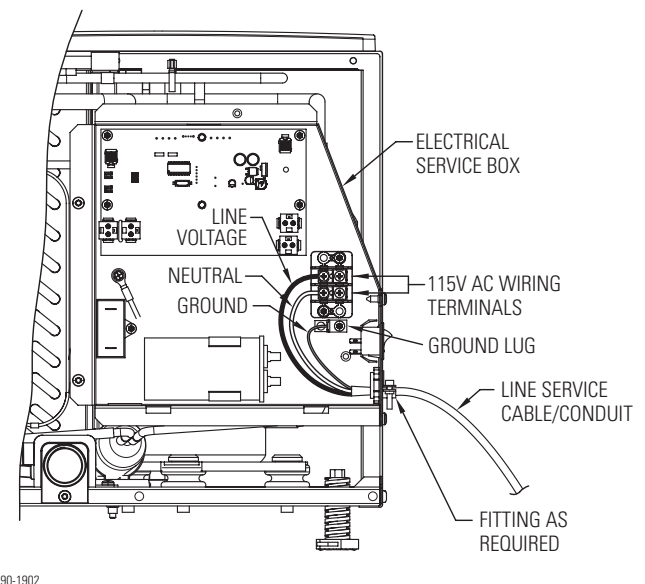
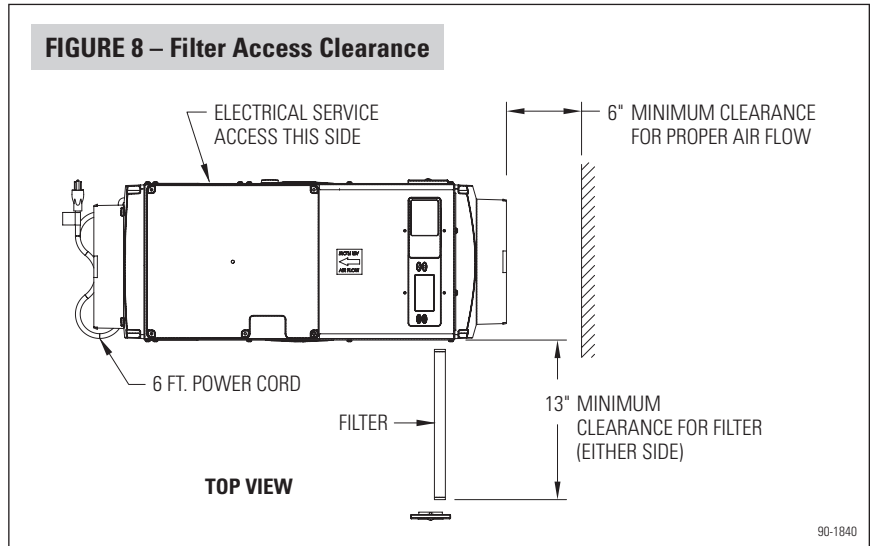

FIGURE 7 – Hard Wire to 115 VAC Service



LOCATION CONSIDERATIONS

- Allow sufficient clearance for filter removal and to prevent airflow obstruction
- Electrical service access will require the removal of the side panel shown. Allow sufficient space for service on this side of the unit.
- If locating the unit in an attic or crawl space, a Model 76 Control mounted in the living space is recommended.
- For attic installations, it is recommended that the dehumidifier be suspended.
- Always install the dehumidifier in a condensate pan when locating in or over a finished space.



DRAIN INSTALLATION

The drain outlet on the dehumidifier can be hard piped using a 3/4" PVC Slip x 3/4" MNPT fitting and 3/4" nominal drain tubing or the provided 3/4" MNPT x 3/4" hose barb fitting and 3/4" clear PVC tubing can be used to drain the dehumidifier. Always maintain a constant downward slope from the dehumidifier to the drain and do not allow soft tubing to curl up which may result in air lock. **NOTE:** PTFE thread seal tape is recommended for the threaded connection and **hand tighten only**. If hard pipe is used, PVC primer and cement is recommended for the slip fit connection.

LEVELING

The feet can be adjusted to level the unit, and if required, to accommodate drain fittings and a secondary condensate pan. Leveling is required to ensure proper drainage from the dehumidifier. See **Figure 9**.

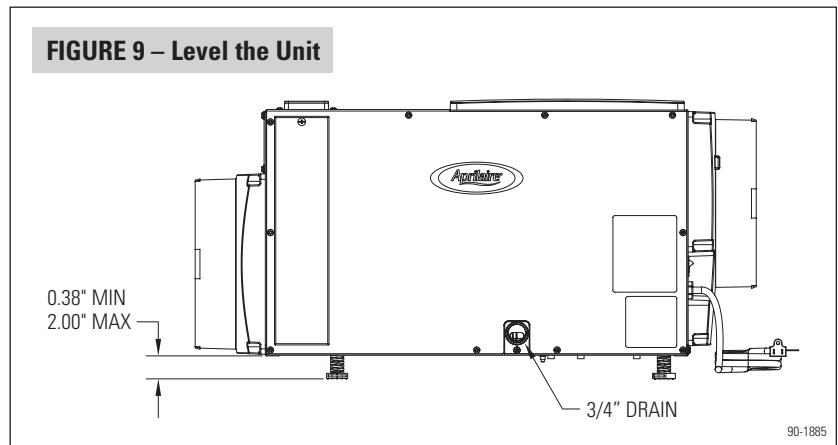

CONDENSATE PAN, CONDENSATE PUMP AND FLOAT SWITCH

Always install the dehumidifier in a condensate pan when locating in or above a finished space. Adhere to local codes regarding draining of the condensate pan. If a condensate pump is needed, install it in the condensate pan as well.

Install a condensate overflow safety switch (i.e. float switch) in the condensate pan, remove the factory installed jumper wire between the Float Switch terminals on the control and wire the float switch to the dehumidifier as shown in **Figure 10**. Overflow safety switches on condensate pumps can be wired to the Float Switch terminals in a similar fashion.

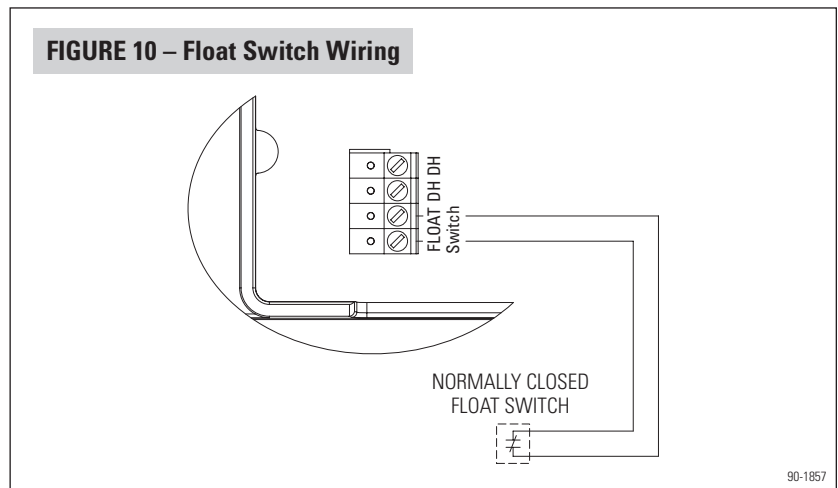

DUCTING TO HVAC SYSTEM – BASEMENT AND ATTIC INSTALLATIONS

The **Preferred Installation** is to duct the dehumidifier to pull air from and return dehumidified air to the HVAC return duct. This installation will ensure warm, dehumidified air is thoroughly mixed with the HVAC system air before being discharged into the living space. Alternatively, the dehumidifier can be ducted to discharge to the supply duct, but the external static pressure of the HVAC system must not exceed 0.4" w.c. for the 1830 and 0.6" w.c. for the 1850/1850W.

Required Component

10" Ductwork

FIGURE 11 – Preferred Basement Installation

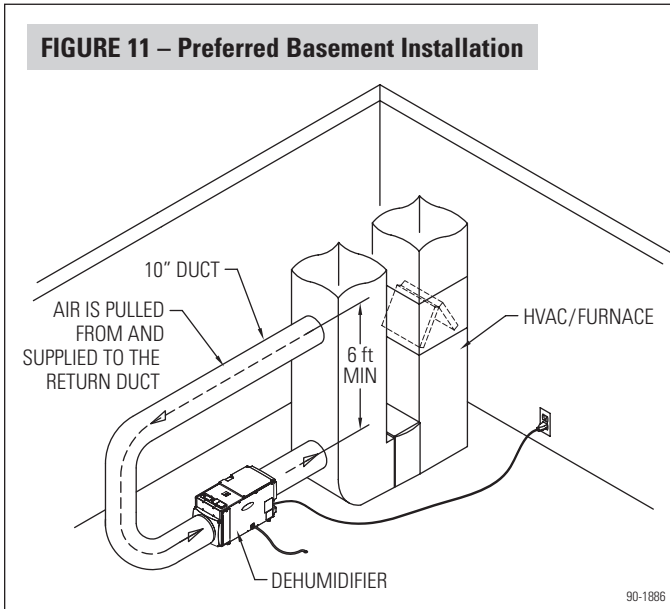

FIGURE 12 – Alternate Basement Installation

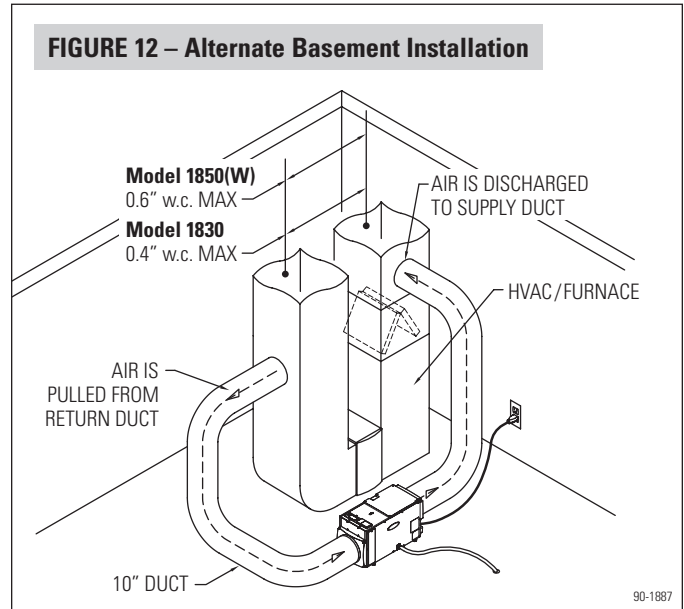

FIGURE 13 – Preferred Attic Installation

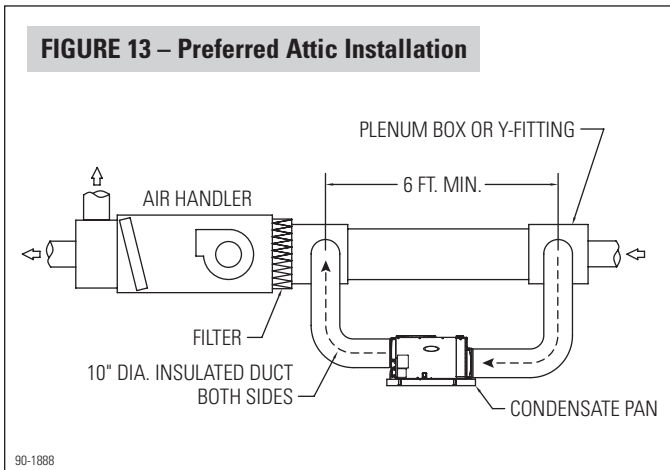
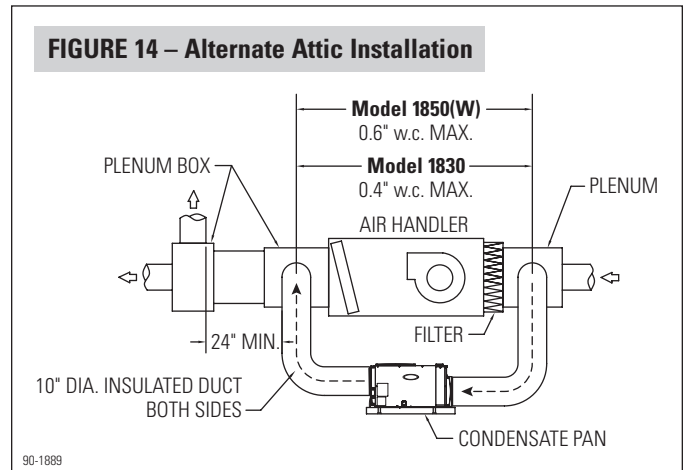

FIGURE 14 – Alternate Attic Installation



Ducting Notes:

- Use insulated duct when the dehumidifier is located in an unconditioned space such as an attic or a garage.
- Use a minimum of 12" of flex duct at the dehumidifier inlet and outlet to prevent vibration noise transmission.
- When ducting return to return (preferred), the dehumidifier must be wired to turn on the HVAC fan when operating (see page 14).
- When ducting return to supply, allow adequate space before the first branch duct to ensure the warm dehumidified air is thoroughly mixed with the HVAC system air.

DUCTING TO HVAC SYSTEM – CLOSET INSTALLATIONS

The dehumidifier in these applications is typically installed under or next to the HVAC equipment. In both types of installation, the dehumidifier inlet is not ducted and pulls from the living space through a grille or louvers in the HVAC closet door. The **Preferred Installation** is to locate the dehumidifier under the HVAC equipment and supply dehumidified air through the alternate outlet on the top of the unit directly to the HVAC return. **NOTE:** The dehumidifier must be wired to activate the HVAC fan during dehumidifier operation in this installation. In the **Alternate Installation** the dehumidifier is located next to the HVAC equipment and ducted to the HVAC supply duct using the outlet on the top of the unit. The supply side external static pressure of the HVAC system must not exceed 0.4" w.c. for the 1830 and 0.6" w.c. for the 1850/1850W.

⚠ CAUTION

When installing the dehumidifier as part of a combustion type furnace (gas, oil, propane, etc.) HVAC system located in a closet, duct or locate the dehumidifier inlet and outlet and seal as needed to separate the circulation air from the combustion and ventilation air. Follow all local and national building and safety codes when installing or modifying any HVAC system.

Optional Component

10" Ductwork

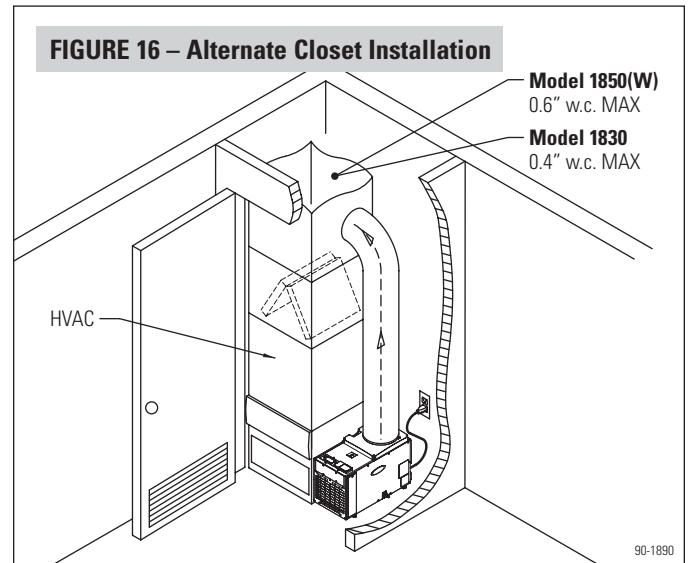
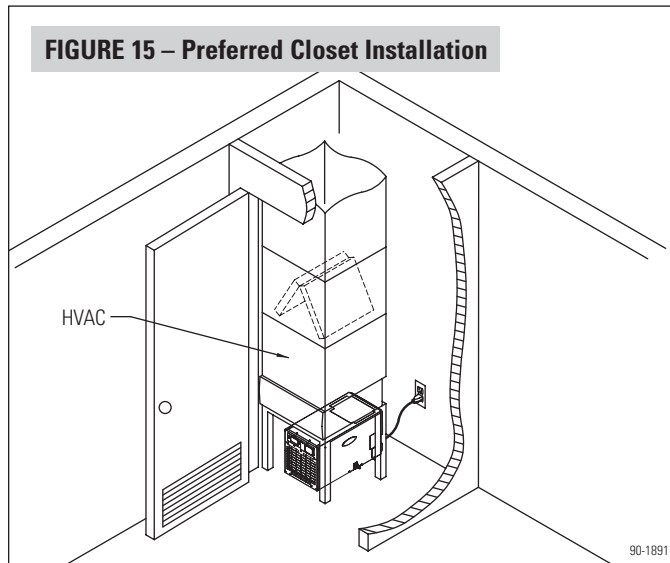

DUCTING FOR STAND ALONE INSTALLATIONS OR NON-DUCTED INSTALLATIONS

In this installation the dehumidifier is not ducted to the HVAC system and is used to dehumidify a specific area. This installation is typically in basements or crawl spaces.

Optional Components

10" Ductwork

Grilles with 10" Duct Collars

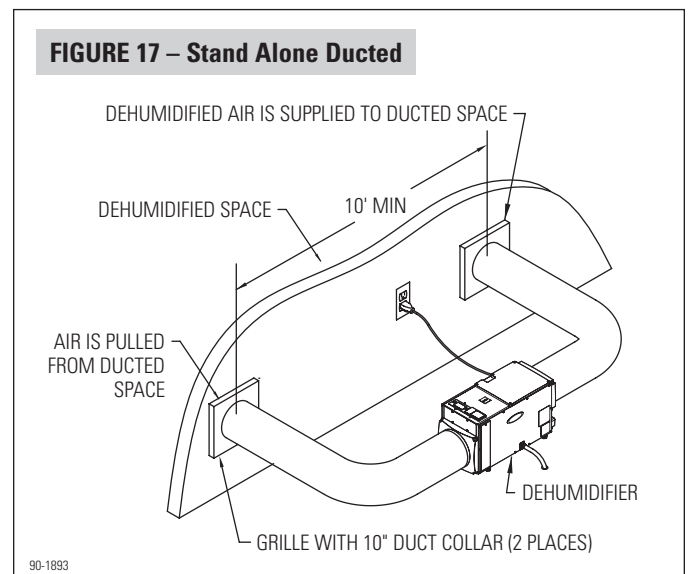

DUCTING FOR TWO ZONE INSTALLATIONS

NOTE: Dehumidifier zoning is not recommended in HVAC zoning applications.

In this installation the dehumidifier controls the humidity in two separate zones, a Primary and Secondary Zone. The dehumidifier will dehumidify the Primary Zone as the first priority, and will switch to the Secondary Zone after the dehumidification needs of the Primary Zone have been satisfied.

IMPORTANT: Normally Closed dampers must be installed in the ducts serving the Primary Zone and Normally Open dampers installed in the ducts serving the Secondary Zone.

Required Components

10" Ductwork and Fittings

Grilles with 10" Duct Collars

Drain Line

2 – Aprilaire Model 6510, 10" Normally Closed Damper

2 – Aprilaire Model 6610, 10" Normally Open Damper

24 VAC Transformer (40VA min.) for Dampers

NOTE: 5442 Basement Kit includes 2 – 6510 Dampers,
2 – 6610 Dampers and a 24VAC (40VA) transformer

FIGURE 18 – Whole-Home Primary Zone Installation

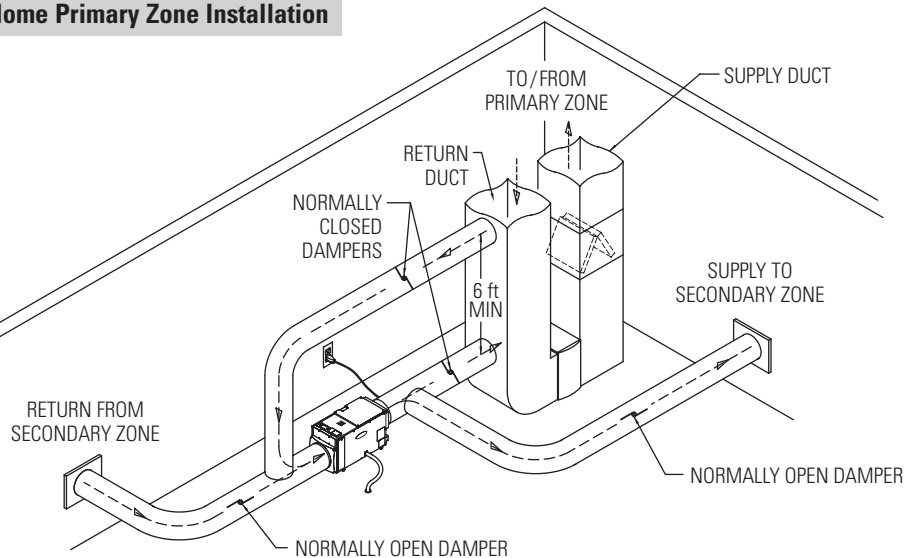

90-1875

FIGURE 19 – Whole-Home Secondary Zone Installation

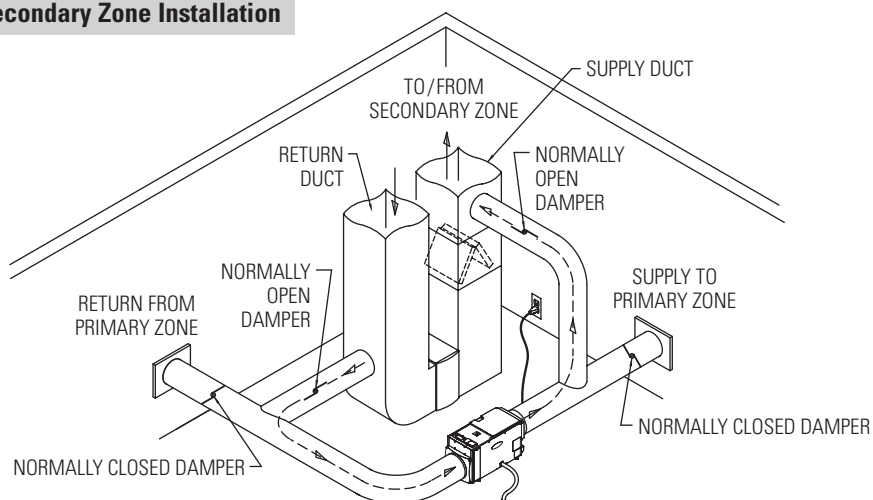

90-1895

MODEL 76 – EXTERNAL CONTROL OR CRAWL SPACE/SEALED ATTIC CONTROL AND WIRING

NOTE: Use 18-22 AWG wire for control wiring.

EXTERNAL CONTROL

Used as an external control, the Model 76 is mounted in the space that is to be dehumidified. When the dehumidifier is powered, the display on the dehumidifier control will show “EXTERNAL” to indicate that an external control is being used. External controls are recommended when the dehumidifier is installed in an attic and is ducted to the HVAC system.

The Model 76 uses a normally open (NO), dry contact (i.e. not a triac or other semiconductor) relay to complete the circuit between the DH terminals of the dehumidifier control. If using other controls such as a thermostat with dehumidification outputs, ensure the output is a dry contact type and set the NO/NC switch on the dehumidifier control (see **Figure 20**) to correspond with the control being used. The Aprilaire Model 8620 Thermostat or Model 8910 Home Comfort Control are recommended alternate controls and both use normally open contacts.

If an external control is used in a zoned application, it must be located in the Primary Zone (refer to TWO ZONE – PRIMARY AND SECONDARY ZONED INSTALLATION on page 18 for details).

CRAWL SPACE/SEALED ATTIC CONTROL

Used as crawl space or sealed attic control (or remote control), the Model 76 is mounted in the living space while the dehumidifier is located in the area to be dehumidified. When the dehumidifier is powered, the display on the dehumidifier control will show “REMOTE” to indicate that a remote control is being used. The RH shown on the Model 76 is the RH measured at the dehumidifier.

Remote control is typically used for crawl space or sealed attic applications, but is also recommended when the dehumidifier and the space being dehumidified are inconvenient or difficult for the homeowner to access. Examples of this type of application include basements that may be inconvenient to access or storage areas.

FIGURE 20 – Model 76 External Control Wiring

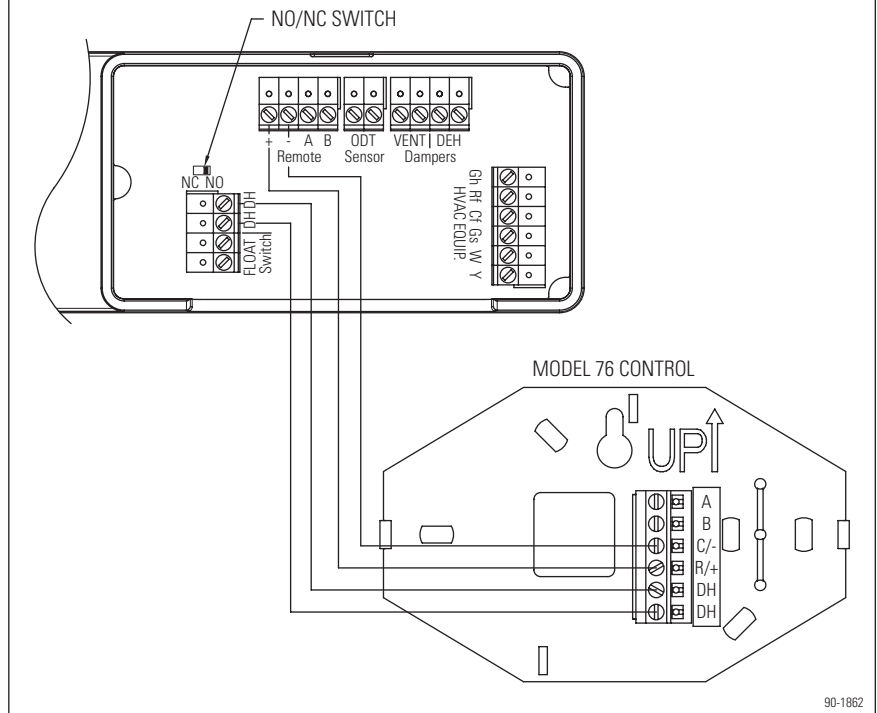
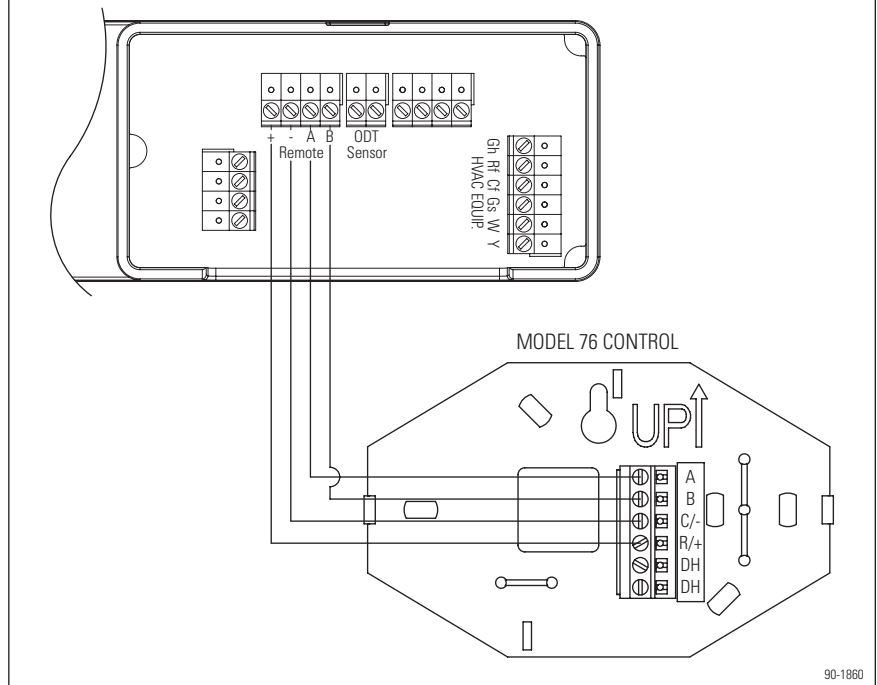

FIGURE 21 – Model 76 Crawl Space/Sealed Attic (Remote) Wiring



WIRING THE DEHUMIDIFIER TO THE HVAC SYSTEM AND ZONE DAMPERS

NOTE: Use 18-22 AWG wire for wiring to HVAC system and zone dampers.

Pull off the wiring access cover near the dehumidifier control to access the wiring terminals. Snap the wiring access cover back into place after completing all wiring.

WIRING TO THE HVAC SYSTEM

When the dehumidifier is ducted to the HVAC system, it is recommended that it also be wired to the HVAC system as shown in **Figure 22**. If ducted to the HVAC system in return to return configuration, the dehumidifier **must** be wired to the HVAC system to prevent short circuiting dehumidified air directly back to the dehumidifier inlet. In return to supply ducting configuration, running the HVAC fan with the dehumidifier ensures the warm dry air is mixed with room air before being discharged to the home.

OPTIONAL W & Y WIRING

Wire the W and/or Y terminal to the HVAC system when using the ventilation feature of the dehumidifier (see VENTILATION on page 19).

Wire the dehumidifier Y terminal to the HVAC system if it is desired to disable the dehumidifier compressor from operating when the air conditioning is running. See **DEH w/AC** in **SYSTEM SET-UP** on page 17 for additional set up steps required to access this feature.

FIGURE 22 – Wiring to HVAC System

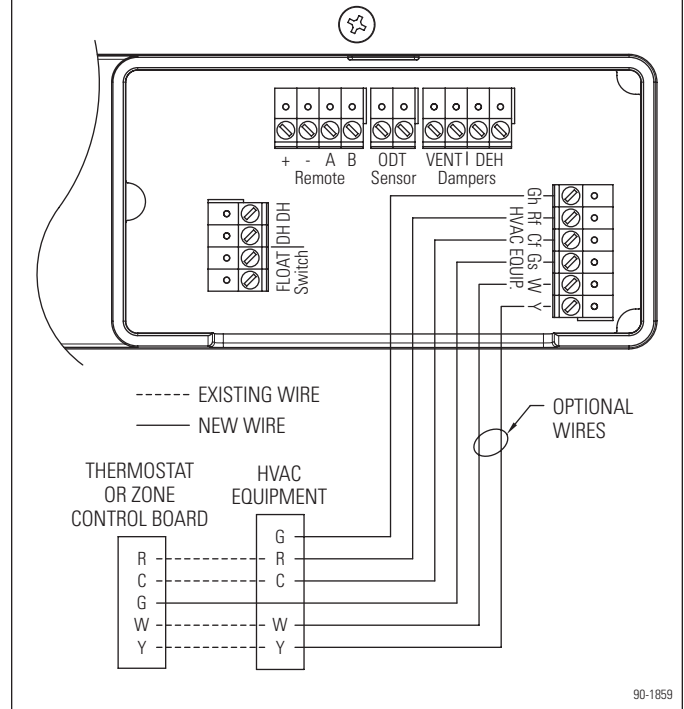

WIRING TO ZONE DAMPERS

FIGURE 23 – Two Zone Wiring On-Board Control

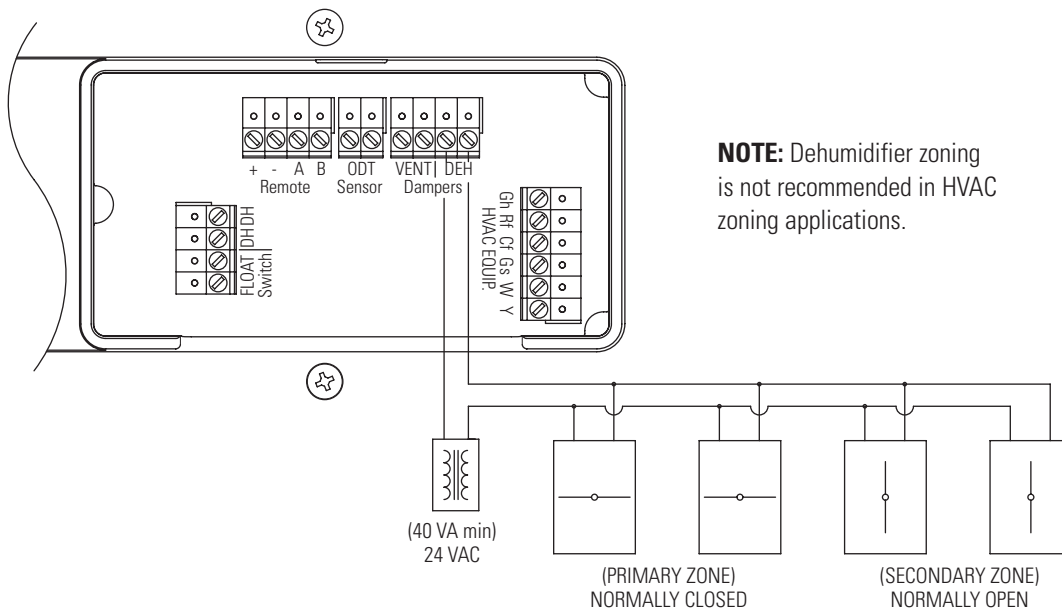

SYSTEM SET-UP & CHECKOUT

If dehumidifier installation does not include ventilation or zoning and will not be wired to an external control, remote control or the HVAC system, proceed to **Installer Test Mode** section on page 17.

1. Check all wiring.
2. Make sure the wire access cover has been snapped back onto the on-board control.
3. Plug unit in and turn power switch to ON.
4. The on-board control screen should display OFF.

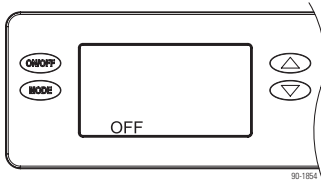

NOTE: If the display backlight is not on, the first button press (any button) will only turn on the backlight. Press the button a second time to achieve function.

5. Hold the MODE button on the on-board control for 3 seconds to enter the Installer Set-up Menu.
6. Navigate through the following screens to set up the dehumidifier for the installed application.
Use the UP or DOWN arrows to select items and use MODE to switch to the next set-up option. To exit installer set-up, all options must be scrolled through using the MODE button.
7. After the installer set up options have been completed, DONE will blink for 3 seconds and the control will return to the OFF screen.

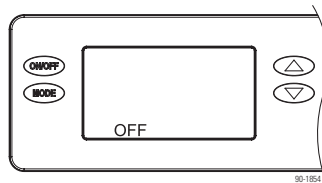
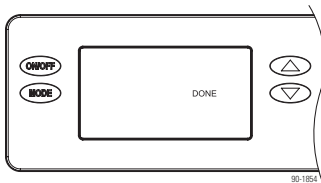

Remote Control – Crawl Space/Sealed Attic

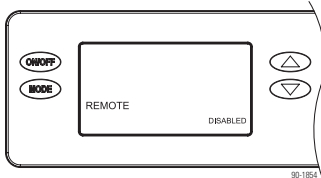

If not installing in a crawl space or sealed attic with Model 76 remote control, press MODE to go to VENT screen selections

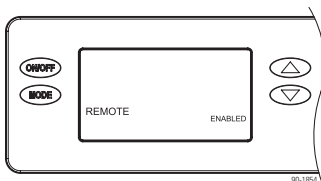

If installing in a crawl space or sealed attic with remote control, Enable and press MODE. The installer set-up is complete, proceed to **Installer Test Mode** section on page 17.

Ventilation

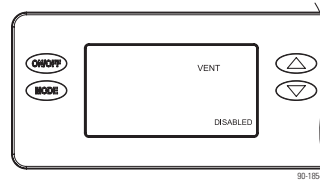

If not using the dehumidifier to bring in outdoor air, press MODE to go to ZONE screen selections.

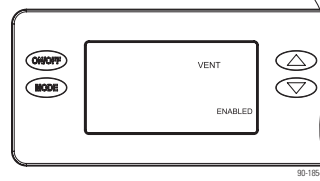

If using the dehumidifier for ventilation, Enable and press MODE to select TIMED or AUTO.

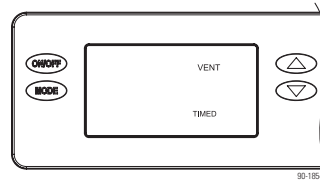

If ventilating based on time only (no outdoor temperature restrictions), press MODE at the VENT TIMED screen to go to ventilation time selection screen.

If ventilating with outdoor temperature restrictions, use the UP arrow to go from VENT TIMED to VENT AUTO –B and then the UP/DOWN arrows to select the desired ventilation mode, B, C, or D. Press MODE to go to the ventilation time selection screen.

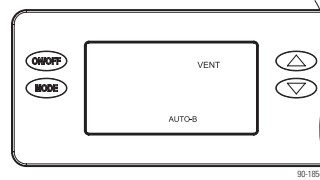

Vent-Auto-B: Ventilation prevented when outdoor temperature is below 0°F and above 100°F. Between 0°F – 20°F ventilation is only allowed during a HVAC heat call.

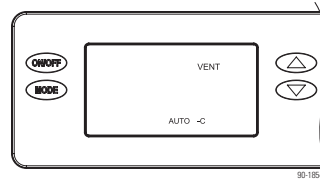

Vent-Auto-C: Ventilation prevented when outdoor temperature is below 0°F and above 100°F.

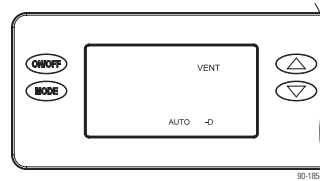

Vent-Auto-D: Ventilation prevented when outdoor temperature is below 0°F and above 90°F. Between 0°F – 40°F ventilation is only allowed during a HVAC heat call.

Vent-Auto-B, -C, -D modes apply outdoor temperature limits and require an outdoor temperature sensor to be installed.

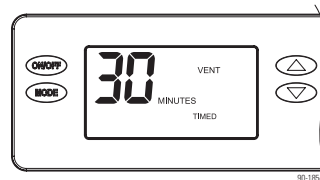

Press the UP or DOWN arrows to adjust the ventilation time per hour from 0 to 60 minutes. After selecting time, press MODE to go to the ZONE screen selections.

SYSTEM SET-UP & CHECKOUT (CONTINUED)

Zone

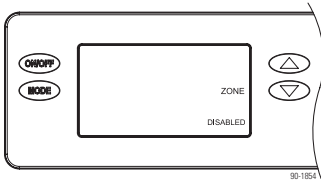

If installing the dehumidifier in a single zone application, select DISABLED and press MODE to go to the EXTERNAL control screen selections.

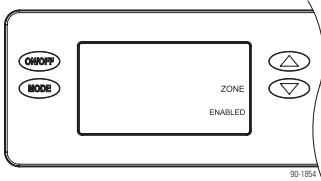

If installing the dehumidifier in a two-zone application, use the UP or DOWN arrows to select ENABLED and press MODE to go to the EXTERNAL control screen selections.

External Control

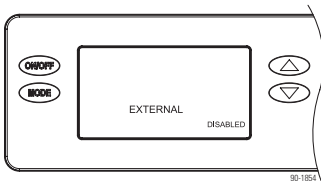

If using the dehumidifier on-board control select DISABLED and press MODE to go to the dehumidification with air conditioning (DEH W/AC) screen selections.

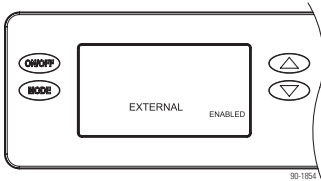

If using a Model 76, Model 8910, or Model 8620 as an external control or other third-party external control, such as a thermostat with dehumidifier outputs, use the UP or DOWN arrows to select ENABLED and press MODE to go to the dehumidification with air conditioning (DEH W/AC) screen selections.

DEH W/AC

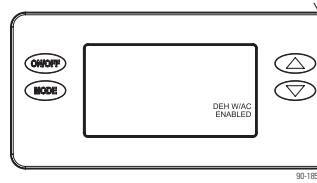

To allow dehumidification during active air conditioning, select ENABLED and press MODE.

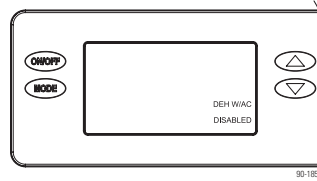

To disable dehumidification when the air conditioning is on, select DISABLED and Press MODE.

RH Offset

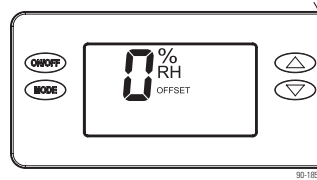

An offset can be applied to the on-board humidity reading to avoid discrepancies with other humidity measuring devices in the home. Use the UP/DOWN arrows to select an offset from -5% to 5%. Press MODE to exit the installer set-up screens.

SYSTEM SET-UP & CHECKOUT (CONTINUED)

Installer Test Mode

If everything is properly wired, the dehumidifier and all of the wired components will turn on and off during Installer Test Mode to demonstrate that all are properly operating. Installer Test Mode lasts for four (4) minutes. If the ON/OFF button is pressed during test mode, the dehumidifier will exit Installer Test Mode and return to the OFF screen.

Dehumidification Only

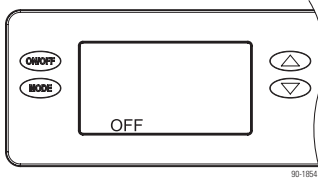

If the dehumidifier is not already OFF, press the ON/OFF button to turn it off.

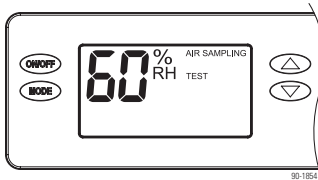

Press and hold the ON/OFF button and MODE buttons for 3 seconds. The measured humidity, AIR SAMPLING and TEST will show on the display. If wired to the HVAC system, the HVAC blower will turn on and if there is/are damper(s) wired to the DEH DAMPER terminals of the control, the damper(s) will energize.

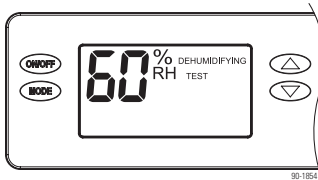

After three (3) minutes the dehumidifier compressor will turn on and DEHUMIDIFYING will replace AIR SAMPLING on the control screen.

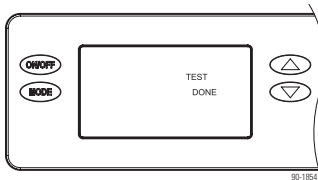

After one minute of compressor operation, all outputs will turn off and DONE will blink for 3 seconds and then return to the OFF screen.

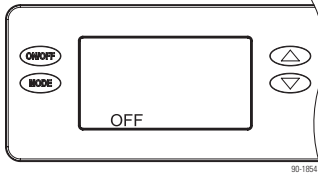

Zoning and/or Ventilation

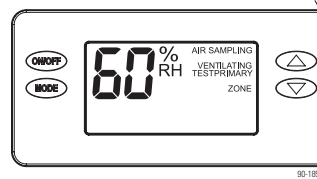

If the dehumidifier has been set up for ventilation, VENTILATING will appear on the display throughout Installer Test Mode, and the ventilation damper will be energized.

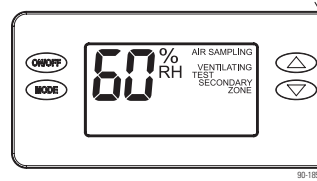

If the dehumidifier has been set up for zoning, PRIMARY ZONE will show on the display for the first minute of dehumidifier blower operation. After one minute, SECONDARY ZONE will show on the display and the zone dampers will de-energize.

START UP AND SEQUENCE OF OPERATION

SINGLE ZONE WHOLE HOUSE OR STAND ALONE USING THE DEHUMIDIFIER CONTROL

1. Press the ON/OFF button to turn the dehumidifier control ON. The display will show the current setting, and the dehumidifier blower and HVAC blower (if wired to the HVAC system) will turn on to start sampling the air.

The setting will be replaced by the measured humidity and "AIR SAMPLING" will show on the display.
2. Use the UP or DOWN button to adjust the humidity setting as desired. The recommended initial setting is 59%.
3. After three (3) minutes of sampling, the measured humidity will be compared to the setting:
 - a. If the humidity is above the setting, the dehumidifier compressor turns on and "AIR SAMPLING" will be replaced by "DEHUMIDIFYING". The compressor remains on until the measured humidity falls 3% RH below the setting.
 - b. If the measured humidity is below the setting, the blowers turn off and the display returns to showing the RH setting.
4. The dehumidifier will sample again every 60 minutes, or at any time if the humidity setting is lowered.

SINGLE ZONE WHOLE HOUSE OR STAND ALONE USING MODEL 76 EXTERNAL CONTROL

1. Press the ON/OFF button to turn the dehumidifier control ON. "EXTERNAL" will show on the display to indicate that an external control is wired to the dehumidifier.
2. At the Model 76, press the ON button; the Model 76 will display the measured RH.
3. Use the UP or DOWN button on the Model 76 to adjust the humidity setting as desired. The recommended initial setting is 59%.
4. If the RH measured by the Model 76 rises above the setting, the dehumidifier will turn on as will the HVAC blower (if wired to the HVAC system). "DEHUMIDIFYING" will appear on the dehumidifier control display to show that the Model 76 is calling for dehumidification. The dehumidifier and HVAC blower (if on) will turn off when the RH measured by the Model 76 drops 3% RH below the setting.

CRAWL SPACE OR SEALED ATTIC (REMOTE) CONTROL USING MODEL 76

1. Press the ON/OFF button to turn the dehumidifier control ON. "REMOTE" will show on the display to indicate that a remote control is wired to the dehumidifier.
2. At the Model 76, press the ON button; the Model 76 will display the RH measured at the dehumidifier, and the dehumidifier blower will turn on to start sampling the air.
3. Use the UP or DOWN button on the Model 76 to adjust the dryness level as desired. The dryness levels are from 1 to 7, with 1 being least dry and 7 being most dry; the recommended initial setting is 3.
4. After three (3) minutes of sampling, the measured humidity will be compared to the setting:
 - a. If the humidity is above the setting, the dehumidifier compressor turns on and "ON" flashes on the Model 76 display.
 - b. If the measured humidity is below the setting, the dehumidifier blower turns off.
5. The dehumidifier will sample again every 60 minutes, or at any time if the dryness level is increased.

TWO ZONE – PRIMARY AND SECONDARY

1. Press the ON/OFF button to turn the dehumidifier control ON.

Dehumidification of the Primary Zone follows the same sequence as described to the left for Single Zone, with or without a Model 76 external control installed in the Primary Zone. The dehumidifier control display will show "PRIMARY ZONE" in addition to that described to the left when sampling or dehumidifying the Primary Zone. The zone dampers are energized when sampling or dehumidifying the Primary Zone.
2. The Secondary Zone uses the humidity setting on the dehumidifier control. During Secondary Zone sampling or dehumidification, the zone dampers are de-energized and the HVAC blower (if on) stops. "SECONDARY ZONE" will show on the dehumidifier control display when the Secondary Zone is either sampling or dehumidifying. If the Primary Zone had just finished a dehumidification demand, the compressor will continue to run during Secondary Zone sampling to prevent short cycling of the compressor.

The Secondary Zone is sampled immediately after the Primary Zone has finished sampling, or if there is a call for dehumidification from the Primary Zone, immediately after the call has been satisfied. When a Model 76 external control is installed, the Secondary Zone will be sampled once per hour if there has not been a call for dehumidification from the Primary Zone. Secondary Zone sampling will also occur whenever the setting on the dehumidifier control is lowered.

VENTILATION

The dehumidifier can activate a normally closed damper to bring in outdoor air through a fresh air intake duct. This feature can not be used when a Model 76 has been installed in a Remote Control application, and is not recommended for two-zone installations.

Required Components

- Aprilaire Model 6506, Normally Closed Damper
- 6" Insulated Duct for Fresh Air Intake Duct
- 24 VAC Transformer (10VA min.) for Ventilation Damper Intake Hood
- 18-22 AWG Wire

Optional Components

- 8052 Outdoor Temperature Sensor

INSTALLATION & WIRING

FIGURE 24 – Single Zone, On-Board Control Ventilation Installation

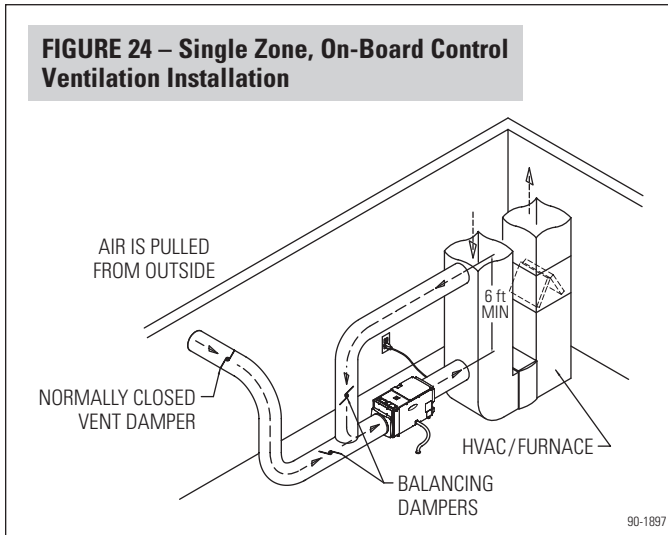

FIGURE 25 – Single Zone, External Control Ventilation Installation

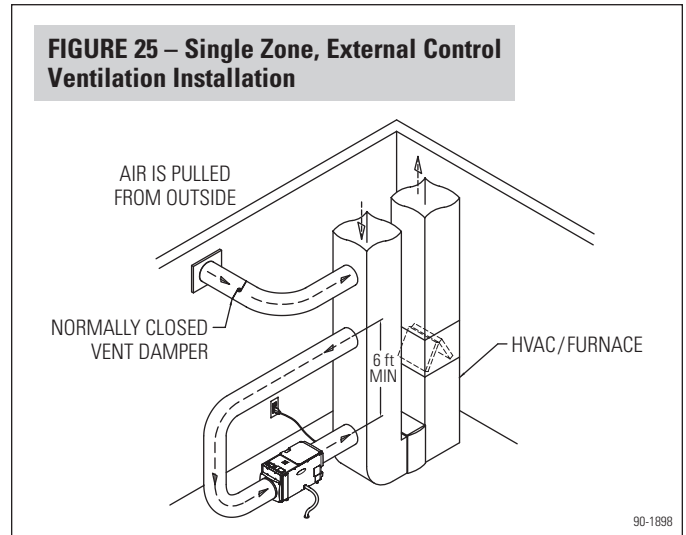
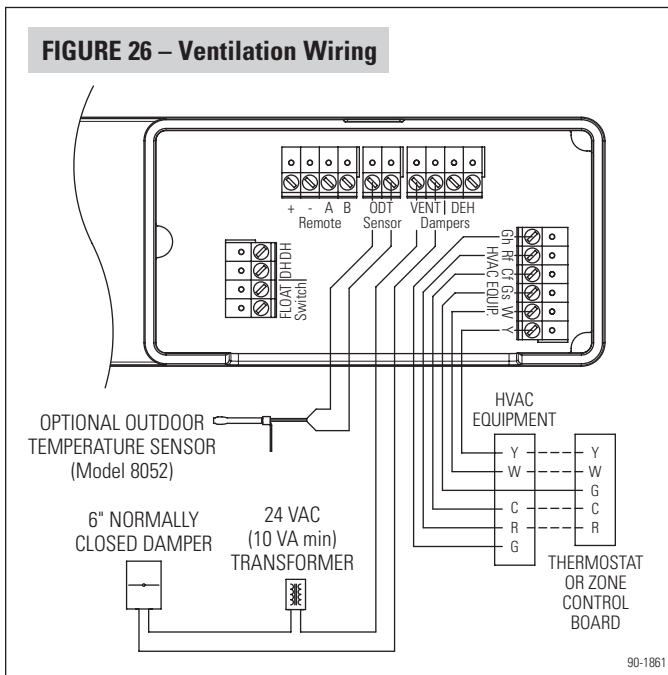

FIGURE 26 – Ventilation Wiring



VENTILATION (CONTINUED)

VENT-AUTO & VENT-TIMED

The dehumidifier can ventilate in four modes.

Vent-Timed: Ventilation occurs based only on time setting; no temperature restrictions.

Vent-Auto-B: Ventilation prevented when outdoor temperature is below 0°F and above 100°F. Between 0°F – 20°F ventilation is only allowed during a HVAC heat call.

Vent-Auto-C: Ventilation prevented when outdoor temperature is below 0°F and above 100°F.

Vent-Auto-D: Ventilation prevented when outdoor temperature is below 0°F and above 90°F. Between 0°F – 40°F ventilation is only allowed during a HVAC heat call.

Vent-Auto-B, -C, -D modes apply outdoor temperature limits and require an outdoor temperature sensor to be installed.

OUTDOOR TEMPERATURE SENSOR INSTALLATION

The Outdoor Temperature Sensor should be installed outside in a shaded location, or in the outdoor air intake duct.

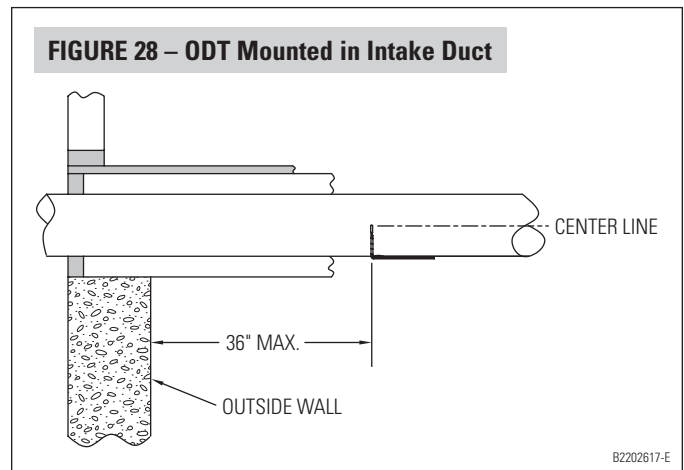
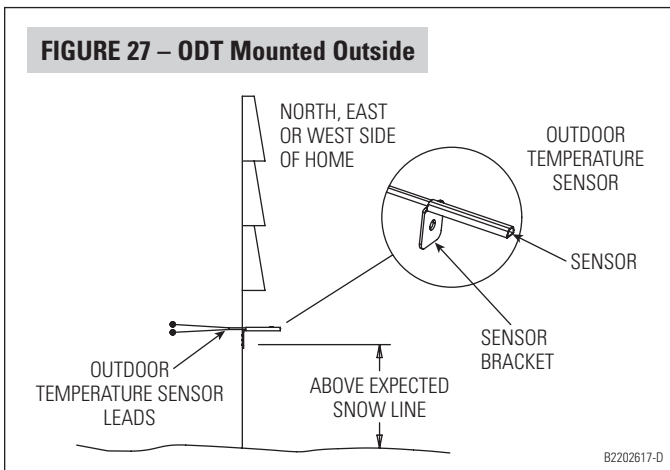

VENTILATION (CONTINUED)

DETERMINE VENTILATION REQUIREMENTS

CALCULATING AIRFLOW REQUIREMENT

1. The MINIMUM ventilation requirement is calculated using ASHRAE 62.2-2010.

$$\text{ASHRAE Airflow in CFM} = [\text{House Area in Sq. Ft.} \times 0.01] + [(\text{Number of Bedrooms} + 1) \times 7.5]$$

NOTE: Use 'Number of Bedrooms + 1' or 'Number of Occupants', whichever is larger.

2. **Table 1** shows the calculated airflow values to the nearest 5 CFM.
3. Record the required CFM. _____

TABLE 1 – CFM Required					
House Sq. Ft.	Number of Bedrooms				
	2	3	4	5	6
1000	35	40	50		
1500	40	45	55	60	70
2000	45	50	60	65	75
2500	50	55	65	70	80
3000	55	60	70	75	85
3500			75	80	90

DETERMINE FRESH AIR DELIVERY RATE

1. Measure the negative static pressure of the return system at the location where the fresh air intake duct enters the return duct or dehumidifier inlet.
2. See **Table 2** for estimated inlet airflow in CFM, based on duct type, length and available negative pressure. Use an airflow measuring device for a more accurate airflow delivery rate.
3. Record the delivered CFM. _____

TABLE 2 – CFM Delivered												
Duct Length	Negative Static Pressure ("w.c.) as Measured for Return Duct or Plenum											
	0.05		0.1		0.15		0.2		0.25		0.3	
	Flex	Pipe	Flex	Pipe	Flex	Pipe	Flex	Pipe	Flex	Pipe	Flex	Pipe
10 ft.	60	65	85	90	105	110	120	125	135	140	150	160
20 ft.	55	60	80	85	100	105	115	120	130	135	140	150
30 ft.	50	55	75	80	95	100	110	115	125	130	130	140

NOTE: For the table above, 6" flex duct is laid loose with two, wide 90° bends and a fully opened damper. Rigid pipe values are based on 6" duct, two 90° elbows, and a fully open damper. In both cases, the air intake is through a metal vent hood with inlet screen. Airflow may need to be adjusted up or down for variations in duct work.

DETERMINE CYCLE TIME

1. Use the Required CFM and Delivered CFM from the above steps to determine the Cycle Time from **Table 3**.
2. The values highlighted in gray cannot be set due to the maximum 60 minute Cycle Time. A second ventilation device (i.e., bigger duct or second duct) will be required to meet ventilation needs.

VENTILATION (CONTINUED)

TABLE 3 – Cycle Time Setting (minutes) for Airflow Delivered vs. Airflow Required for 1 hour Cycle

CFM Delivered	CFM Required								
	20	30	40	50	60	70	80	90	100
60	20	30	40	50	60	70	80	90	100
80	15	25	30	40	45	55	60	70	75
100	15	20	25	30	35	40	50	55	60
120	10	15	20	25	30	35	40	45	50
140	10	15	15	20	25	30	35	40	45
160	10	10	15	20	25	25	30	35	40

INSTALLER SETTINGS

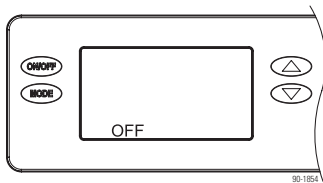

With the dehumidifier power switch on, press the ON/OFF button to turn the dehumidifier off.

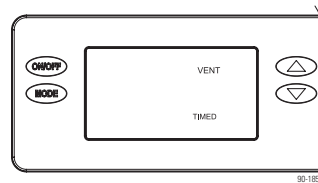

Press the UP or DOWN to toggle between VENT TIMED, VENT AUTO-B, VENT AUTO-C and VENT AUTO-D (refer to page 20 for a description of each). Press the MODE button to select the desired ventilation method and adjust the ventilation time.

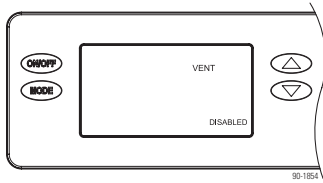

Press and hold the MODE button for 3 seconds to access the installer settings menu. Press and release the MODE button repeatedly until the VENT DISABLED screen appears.

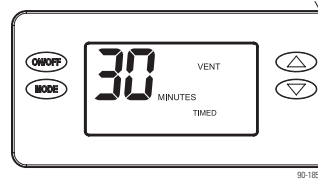

Press the UP or DOWN button to set the desired amount of ventilation time per hour from 0 to 60 minutes.

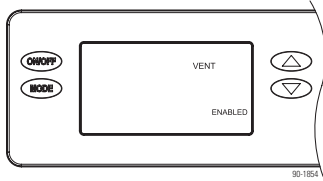

Press the UP or DOWN button to ENABLE ventilation, then press the MODE button to set Timed or Auto ventilation.

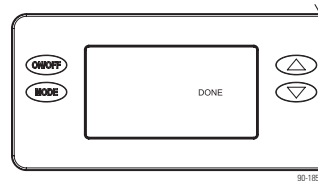

To complete, press the MODE button repeatedly until DONE appears on the display.

VENTILATION (CONTINUED)

SEQUENCE OF OPERATION

When wired as shown in **Figure 26**, the ventilation damper will open whenever there is an HVAC heating (W), cooling (Y) or fan (Gs) call, allowing fresh air to be brought in when the HVAC blower is running (see VENTILATION WITH AN EXTERNAL CONTROL section below for exceptions). The ventilation damper will also open if the dehumidifier is operating. "VENTILATING" will show on the dehumidifier control when the dehumidifier is actively ventilating. When the HVAC call ends, the dehumidifier stops, or after the set amount of ventilation time has been met, the ventilation damper will be closed.

If the set amount of ventilation time has not been met before the end of the one-hour cycle, the dehumidifier will turn on the ventilation damper along with the HVAC blower to ensure the desired ventilation time is satisfied.

If the dehumidifier has been set up to operate ventilation with outdoor temperature restrictions (AUTO-B, AUTO-C or AUTO-D – refer to page 20) then ventilation will be limited as described.

DEHUMIDIFYING THE FRESH AIR

When the dehumidifier is set up for single zone and there is no external control installed, the dehumidifier will turn on its blower and measure the RH of the air entering the dehumidifier during ventilation when ducted as shown in **Figure 24**. If the relative humidity of the air entering the dehumidifier is higher than the setting, the dehumidifier compressor will turn to remove moisture.

VENTILATION WITH AN EXTERNAL CONTROL

When an external control is installed the dehumidifier will open the ventilation damper only when there is a cooling call (Y) or when the dehumidifier is operating, unless the ventilation need has not been met. If the set amount of ventilation time has not been met before the end of the one-hour cycle, the dehumidifier will turn on the ventilation damper along with the HVAC blower to ensure the desired ventilation time is satisfied.

ADJUSTING VENTILATION TIME AFTER INITIAL SET UP

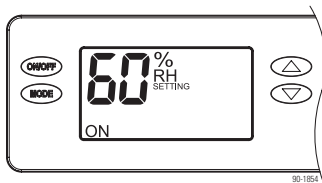

1. Press the UP or DOWN button to access the RH adjustment screen or to turn on the backlight if using an External Control.

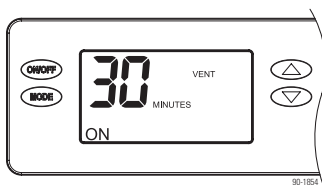

2. Press the MODE button to toggle to the VENT TIME setting.
3. Press the UP or DOWN button to adjust the ventilation time (minutes). After adjusted, press nothing else; the screen will return to home screen after three (3) seconds.

TROUBLESHOOTING

Technical Support is available Monday through Friday, 7:00 a.m. to 5:00 p.m. CST, at (800) 334-6011. Use the guides on the following pages to identify and correct system faults. Contact Technical Support before replacing the unit or any components and for additional troubleshooting.

DIAGNOSTIC CODES

When an error occurs, the Diagnostic Code along with SERVICE REQUIRED will be displayed on the control screen.

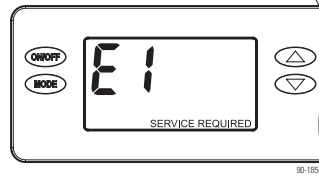

99-1854

TABLE 4 – Diagnostic Codes

Diagnostic Code	Failure Mode	Action	Reset
E1	Internal Humidity or Temperature Sensor Open or Shorted	<ol style="list-style-type: none"> 1. Check the connection between the sensor board and control board. 2. If connection okay, replace sensor board, Part No. 5460. 	Cycle Power
E2	High Refrigeration Pressure	<ol style="list-style-type: none"> 1. Verify that the fan works, the backflow damper swings freely and there is no blocked or restricted ductwork. 2. If the fault persists, call Technical Support. 	Cycle Power
E3	Model 76 Remote Control Communication Loss	<ol style="list-style-type: none"> 1. Check connections between Model 76 and dehumidifier control board. Terminals should be fully inserted and secured in the control board and Model 76 control terminals. 2. If connections are correct and secure, turn off the dehumidifier and remove the Model 76. Use a short section of 4-wire cable to reconnect the Model 76 to the control board. Turn the dehumidifier back on and increase the dryness level setting on the Model 76. If the dehumidifier turns on, the problem is with the wiring between the dehumidifier and control. 3. If the dehumidifier does not turn on, call Technical Support. 	Self-Correcting
E4	Insufficient Capacity	<ol style="list-style-type: none"> 1. Check the frost sensor connection at the power board. Terminal should be fully seated on the power board pins. 2. Remove the side access panel and verify that the sensor is secured to the suction line. 3. If the sensor is connected and secured to the refrigeration line proceed to the next step. 4. Reset the fault by cycling power to the dehumidifier. 5. Turn the humidity setting down (below room/home humidity level) to make a dehumidification call. 6. Allow the fan and compressor to run for approximately 10-15 minutes and then enter diagnostic test mode by simultaneously pressing the UP ARROW and MODE buttons for 3 seconds. The LCD will display the temperature measured by the internal sensor while also displaying AIR SAMPLING and ON, the humidity measured by the internal sensor while also displaying %RH and ON, and the frost sensor temperature while also displaying ON. Scroll through these values and by using the UP/DOWN arrow buttons. 7. Record values and call Technical Support. 	Cycle Power
E5	High Temperature Thermistor Failure	<ol style="list-style-type: none"> 1. Check the high temperature sensor connection at the power board. Terminal should be fully seated on the power board pins. 2. Remove the side access panel and verify the sensor is not damaged and connected to the refrigeration line coming from the compressor. 3. If the sensor is connected and secured to the refrigeration line, it may need to be replaced with Part No. 5456 – contact Technical Support to confirm. 	Cycle Power
E6	Low Temperature Thermistor Failure	<ol style="list-style-type: none"> 1. Check the low temperature sensor connection at the power board. 2. Remove the side access panel and verify the sensor is not damaged and connected to the suction line. 3. If the sensor is connected and secured to the refrigeration line, it may need to be replaced with Part No. 5455 – contact Technical Support to confirm. 	Cycle Power

TROUBLESHOOTING (CONTINUED)

TABLE 4 – Diagnostic Codes (continued)

Diagnostic Code	Failure Mode	Action	Reset
E7	Float Switch Open	<ol style="list-style-type: none"> 1. Empty the condensate pan. 2. Check the float switch connection at the control board. 3. If not using a float switch, verify jumper is between float switch terminals on dehumidifier control board. 4. If the problem persists, replace the float switch. 	Self-Correcting
E8	Inlet Air Temperature Out of 50°F – 104°F range, or dew point below 40°F	<ol style="list-style-type: none"> 1. Verify all ductwork is properly sealed. 2. If no signs of leak points, contact Technical Support. 	Self-Correcting
E9	Outdoor Temperature Sensor Open or Shorted	<ol style="list-style-type: none"> 1. Check the sensor connection at the power board. 2. Remove the wires from the terminals and measure the resistance. A short circuit will have a resistance very close to 0 Ohms and an open circuit will have a very very high resistance. The table at right can be used to approximate the resistance based on outdoor temperature. 3. If the sensor is not reading correctly, replace the sensor, Part No. 8052. 	Self-Correcting

Outdoor Temperature	Resistance
0°F	84,500 Ohms
20°F	46,000 Ohms
40°F	26,000 Ohms
60°F	15,500 Ohms
80°F	9,500 Ohms
100°F	6,000 Ohms

TROUBLESHOOTING (CONTINUED)

TABLE 5 – Troubleshooting Guide

Symptom	Possible Reason	Troubleshooting Procedure													
Dehumidifier does not turn on/run.	No power to unit.	<ul style="list-style-type: none"> • Check that the dehumidifier is plugged in. • Check that the power switch is turned ON. • Check that the control is turned ON. • Check that the circuit breaker has not tripped. 													
Dehumidifier blower is running but with little or no airflow.	Pressure drop across dehumidifier is higher than 0.4" w.c. for Model 1830 or 0.6" w.c. for Model 1850/1850W.	<ul style="list-style-type: none"> • Check dehumidifier air filter and wash or replace. • Check for blocked duct work and clear. • Verify that the outlet collar with backflow damper is installed on the outlet side of the dehumidifier. • Check if backflow damper is blocked or stuck and remove obstruction. 													
Dehumidifier blower is running but compressor is not.	Float switch open.	<ul style="list-style-type: none"> • If float switch installed, check connections at control board and empty condensate pan. • If no float switch installed check that the jumper is installed at the float switch terminals on the control board. 													
	Coil frosting.	<ul style="list-style-type: none"> • Lack of or reduced airflow. Check dehumidifier air filter and wash or replace. • Check for blocked duct work. • Inlet air conditions below 60°F. Increase the humidity setting. 													
	Inlet air temperature is outside of the 50°F – 104°F range or the dew point is below 40°F and there is a demand for dehumidification.	<ul style="list-style-type: none"> • Verify all ductwork is properly sealed. 													
When zoned, the dehumidifier damper does not open in INSTALLER TEST mode.	Incorrect damper wiring or bad connection.	<ul style="list-style-type: none"> • Verify wiring between dampers and 24 VAC transformer. • If wired for Two Zone operation, verify that 24 VAC transformer is 40 VA minimum. • Check all wiring connections between dampers and control board. • Verify the normally closed dampers are in the Primary Zone ductwork and the normally open dampers are in the Secondary Zone ductwork. 													
The ventilation damper does not open when the HVAC fan is active.	Cycle time has been met.	<ul style="list-style-type: none"> • The damper will not open if the Ventilation Time has already been met. 													
	ODT error or outdoor air outside of ODT range.	<ul style="list-style-type: none"> • Check that the ODT is wired correctly to the dehumidifier control board and connections are secure. • Check that the ODT is installed in the outdoor air intake according to the set-up specified in the Ventilation Section beginning on page 19. • Remove the ODT leads from the dehumidifier control board and check the resistance. Compare the reading with the table shown. <table border="1" data-bbox="1101 1262 1438 1520"> <thead> <tr> <th>Outdoor Temperature</th> <th>Resistance</th> </tr> </thead> <tbody> <tr> <td>0°F</td> <td>84,500 Ohms</td> </tr> <tr> <td>20°F</td> <td>46,000 Ohms</td> </tr> <tr> <td>40°F</td> <td>26,000 Ohms</td> </tr> <tr> <td>60°F</td> <td>15,500 Ohms</td> </tr> <tr> <td>80°F</td> <td>9,500 Ohms</td> </tr> <tr> <td>100°F</td> <td>6,000 Ohms</td> </tr> </tbody> </table>	Outdoor Temperature	Resistance	0°F	84,500 Ohms	20°F	46,000 Ohms	40°F	26,000 Ohms	60°F	15,500 Ohms	80°F	9,500 Ohms	100°F
Outdoor Temperature	Resistance														
0°F	84,500 Ohms														
20°F	46,000 Ohms														
40°F	26,000 Ohms														
60°F	15,500 Ohms														
80°F	9,500 Ohms														
100°F	6,000 Ohms														
Dehumidifier is not draining properly.	Drain line blocked or unit not level.	<ul style="list-style-type: none"> • Verify that the unit is level. • Check the drain line blockages and for a continuous downward slope. 													
The HVAC fan turns on unexpectedly.	Dehumidifier is sampling or ventilation in progress.	<ul style="list-style-type: none"> • The dehumidifier will turn on the HVAC fan during air sampling or as needed to meet the ventilation time. 													
Dehumidifier is producing hot air.	Normal function.	<ul style="list-style-type: none"> • Air is reheated across the condenser coil, resulting in a temperature rise between inlet and outlet. 													

SERVICE PARTS

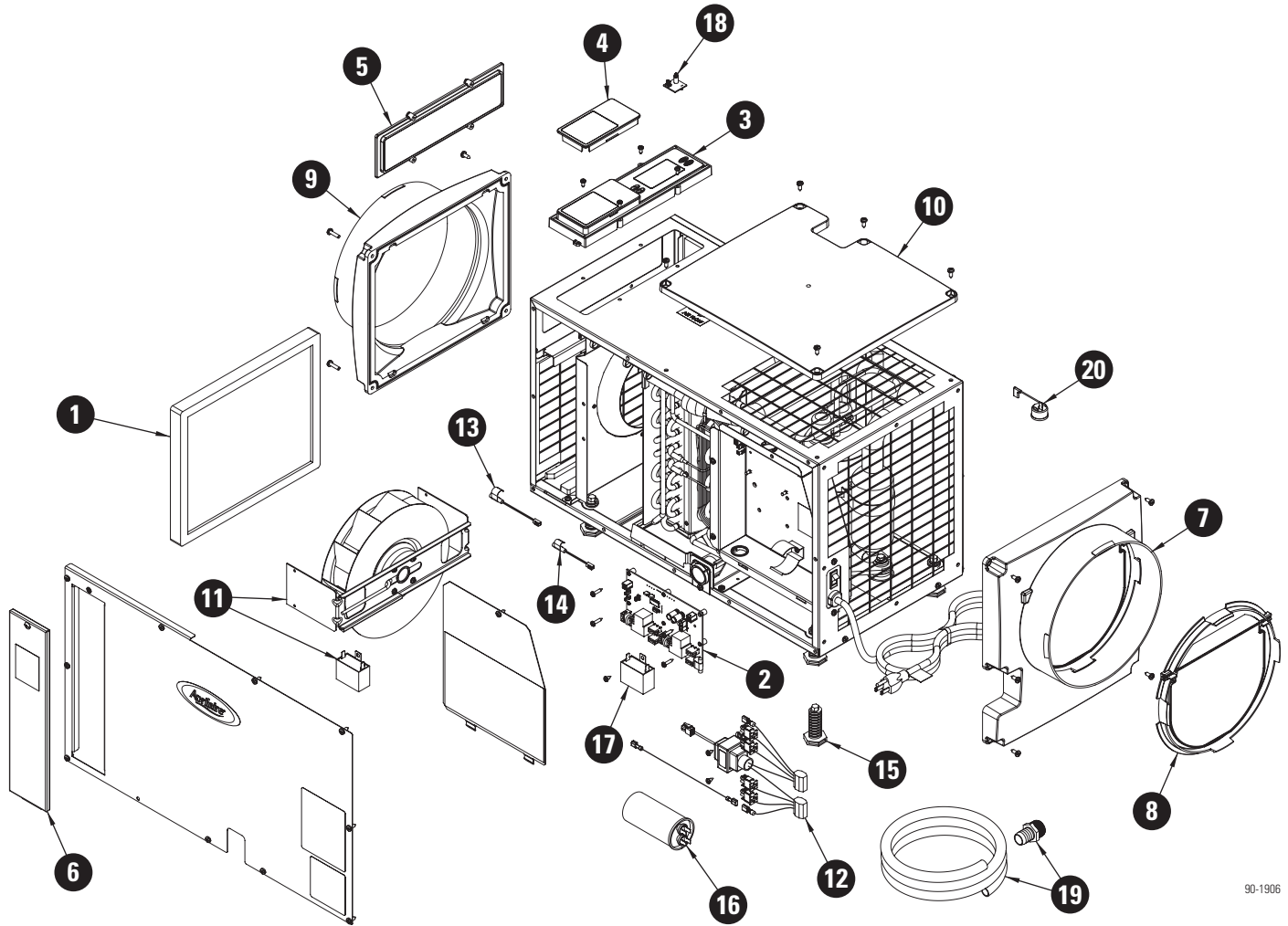

90-1906

No.	Part Description	Part No.
1	Filter, 10" x 12" x 1" EZK	5443
2	Internal Control Board, Deh	5444
3	User Interface Assembly, Deh	5445
4	Wiring Access Door, AA Deh	5446
5	Hole Cover, UI Ctrl, Deh	5447
6	Door, Filter Access, AA Deh	5448
7	Outlet Duct Panel, Deh	5449
8	Backflow Damper, 10", Deh	5450
9	Inlet Duct Panel, AA Deh	5451
10	Cover, Outlet, AA Deh	5452
11	Fan, 70pt Deh, with 6MFD Capacitor	5453
	Fan, 95pt Deh, with 12MFD Capacitor	5467
12	Wire Harness, Power, Deh	5454

No.	Part Description	Part No.
13	Sensor, Low Temperature, Deh	5455
14	Sensor, High Temperature, Deh	5456
15	Leveling Foot, Deh	5457
17	Capacitor, 45MFD, 370VAC, 70pt/95pt Deh	5458
	Capacitor, 8MFD, 450VAC, 70pt Deh, with Serial Number before 112015A09596	5459
	Capacitor, 6MFD, 250VAC, 70pt Deh, with Serial Number 112015A09596 or later	5582
	Capacitor, 12MFD, 450VAC, 95pt Deh	5468
18	RH Sensor, Deh	5460
19	Drain Tube + Fitting	5665
20	Compressor Overload Switch, 70pt Deh	5547
	Compressor Overload Switch, 95pt Deh	5548



P.O. Box 1467 • Madison, WI 53701-1467 • Phone: 800/334-6011 • Fax: 608/257-4357 • www.aprilairepartners.com